

# Chapter 8

## SME as a Service

**José Carlos Martins Delgado**  
*Instituto Superior Técnico, Portugal*

### ABSTRACT

*The market evolves at an increasingly faster pace. Enterprises, and in particular SMEs (Small and Medium Enterprises), besides having to stay agile, competitive and aware of competition, must give customers what they need (customized products or services) when they need it. The classical business paradigm (carefully studying what customers have bought in the past to predict what they will buy in the near future and derive a strategy from it) is not agile and adequate enough anymore. This chapter discusses a customer-centric business paradigm with enough agility to follow the patterns of customers' needs and the ability to customize specific needs as a variant of some pattern, turning the very low volume customer market into a viable business opportunity. The customization and corresponding production result from concrete user requests and not anticipation of demand. We call it EaaS (Enterprise as a Service) and is particularly adequate to SMEs.*

### INTRODUCTION

An enterprise is usually part of a value network (buying from suppliers, selling to customers and managing its own resources, Figure 1a), where it suffers three main types of risks:

- **Supplier side risks:** supplier discontinuing or failing to provide a product/service, betting on a supplier's technology/product that looses on the market;

- **Customer side risks:** customer failing to pay, no purchase orders or cancelations;
- **Its own risks:** bad strategy, unattractive or uncompetitive products/services, poor supplier, customer or resource management, inability to deal with supplier capacity/customer demand mismatch, insufficient or inadequate resources, hazards.

Each enterprise tries to minimize these risks in various ways. One basic technique is diversification (second source suppliers, broad client base, diversified product/service offerings), but dealing

DOI: 10.4018/978-1-4666-3886-0.ch008

Figure 1. Modeling an EA: (a) structure and (b) metamodel

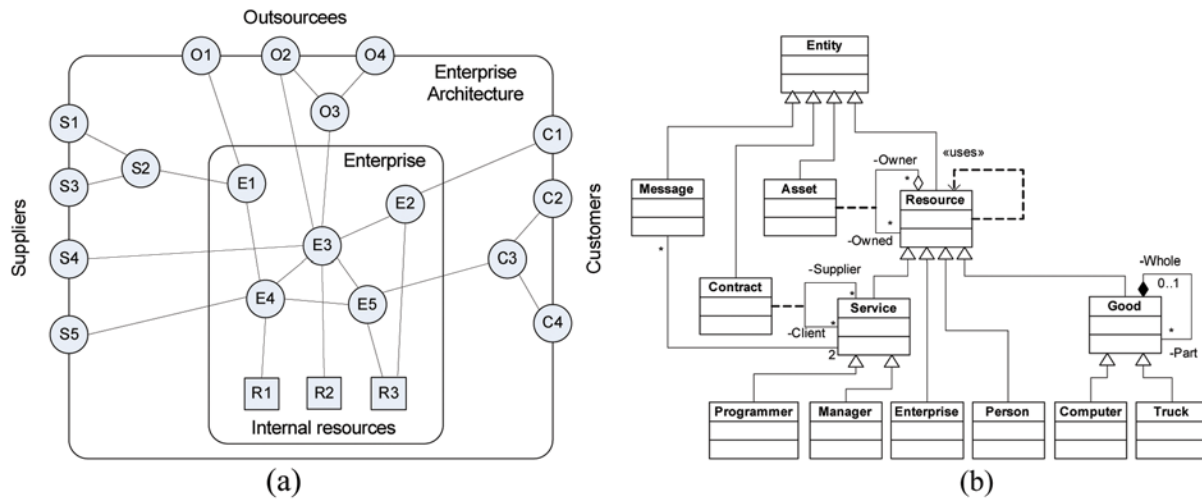

with many suppliers, customers and products/services adds to entropy and entails its own costs and risks.

SMEs (Small and Medium Enterprises) are particularly vulnerable because they have limited resources and are usually neither in a position of imposing on suppliers (not enough business volume) nor of benefiting from economy of scale (most of them operate on the niche, occasional and low volume/item markets, grabbing a share of the market's long tail (Anderson, 2006) that many large enterprises don't bother with). Credibility is also a very important indicator for customers (especially the big, worthwhile ones, which are more averse to risk and prefer large enterprises as suppliers, even if their price is higher).

To be competitive, SMEs have to behave differently from large enterprises operating in the same markets, by taking approaches such as:

- Innovative products/services:** Potentially very rewarding, as getting to a new market first is a huge head start, is also very risky to pull through, not to mention the difficulty of having innovative ideas and the possibility of quickly being overrun by a larger company seizing the idea with a competing product/service;
- Customized solutions:** For customers that have specific requirements and cannot simply use mass products or utility services. This, however, can be man-power intensive, require significant development and management capabilities and face competition from large reconfigurable manufacturing or consulting companies;
- Adaptability:** In today's fast paced world, each opportunity must be seized with efficacy, efficiency and responsiveness. This means providing the customer with the solution that is really needed (not just chewing in some ready-to-sell solution), consuming resources only as needed (TCO, Total Cost of Ownership, as low as possible) and being able to quickly restructuring the way the enterprise operates, if needed. Large companies can be slower to respond, have greater TCO and resource management (that needs to be charged to the customer) and be less akin to adapt to small customers.

Adaptability (the ability to change and adapt to specific or new requirements and goals) is one of the best weapons against competitors that SMEs can resort to in a sustained way. In a

19 more pages are available in the full version of this document, which may be purchased using the "Add to Cart" button on the publisher's webpage:

[www.igi-global.com/chapter/sme-service/75962](http://www.igi-global.com/chapter/sme-service/75962)

## Related Content

---

### Proposed CSR Regulatory Sandbox: Mitigating Greenwashing in Corporate Sustainability Reporting for SMEs in Europe

Renata Thiébaud and Marc Selgas-Cors (2026). *International Journal of SME Research and Innovation* (pp. 1-11).

[www.irma-international.org/article/proposed-csr-regulatory-sandbox/398953](http://www.irma-international.org/article/proposed-csr-regulatory-sandbox/398953)

### Open Innovation Three-Dimensional Model: A Framework for Mapping External Partnerships Applied to SMEs in the FMCG Industry

Fabio Barboza Cabral (2025). *International Journal of SME Research and Innovation* (pp. 1-17).

[www.irma-international.org/article/open-innovation-three-dimensional-model/398629](http://www.irma-international.org/article/open-innovation-three-dimensional-model/398629)

### Conceptual Approaches to Marketing for Improving HR Practices

Prasad Siba Borah (2024). *Innovative Human Resource Management for SMEs* (pp. 212-232).

[www.irma-international.org/chapter/conceptual-approaches-to-marketing-for-improving-hr-practices/337916](http://www.irma-international.org/chapter/conceptual-approaches-to-marketing-for-improving-hr-practices/337916)

### Adoption of Online Marketing for Service SMEs with Multi-Criteria Decision-Making Approach

Lanndon Ocampo, Rosalin Merry Berdin Alarde, Dennis Anthony Kilongkilong and Antonio Esmero (2020). *Start-Ups and SMEs: Concepts, Methodologies, Tools, and Applications* (pp. 356-374).

[www.irma-international.org/chapter/adoption-of-online-marketing-for-service-smes-with-multi-criteria-decision-making-approach/245459](http://www.irma-international.org/chapter/adoption-of-online-marketing-for-service-smes-with-multi-criteria-decision-making-approach/245459)

### Innovation in the Time of Pandemic: Insights from a Survey of Malaysian Small and Medium Enterprises (SMEs)

Mohammed Alnajjar, Abdelhak Senadjki, Au Yong Hui Nee and Samuel Ogbeibu (2025). *International Journal of SME Research and Innovation* (pp. 1-21).

[www.irma-international.org/article/innovation-in-the-time-of-pandemic/368040](http://www.irma-international.org/article/innovation-in-the-time-of-pandemic/368040)