

Chapter 11

Safety System Design Simulation for Transcutaneous Electrical Nerve Stimulator using Electrode Contact Test

Mervin T. Hutabarat

Institut Teknologi Bandung, Indonesia

Subaryani D. H. Soedirdjo

Institut Teknologi Bandung, Indonesia

ABSTRACT

TENS (Transcutaneous Electrical Nerve Stimulator) is a therapeutic device used to deliver electric current through one's skin. As the device is used on the human body, safety concern becomes a matter that needs special attention. One option for electrical safety is testing whether the electrode has attached properly to the skin. The test is done in the interval of the simulator pulse. This option is used to protect users from electrical shock that can be caused from this device. Using 74HC4066 as the analog switch, this design can support the TENS specification.

INTRODUCTION

The purpose of medical equipment is to monitor, treat patient, and improve their condition. Nowadays, medical equipments are mostly automated as electronic control provides high precision and lifetime. Thus, the safety of the device that is use electricity should also be considered, to avoid electrical hazard that can be dangerous and cause death.

OVERVIEW

By definition, any stimulating device that delivers electrical currents across the intact surface of the skin is TENS (Johnson, 2007). In medical term, TENS is one of a simple non-invasive analgesic technique that is used to decrease pain sensation in many conditions such as labor pain, chronic pain, and acute pain. TENS is widely use as its non-invasive characteristic, easy to use, and less of side effects.

DOI: 10.4018/978-1-4666-0909-9.ch011

Figure 1. Systems block diagram (Soedirdjo, 2009)

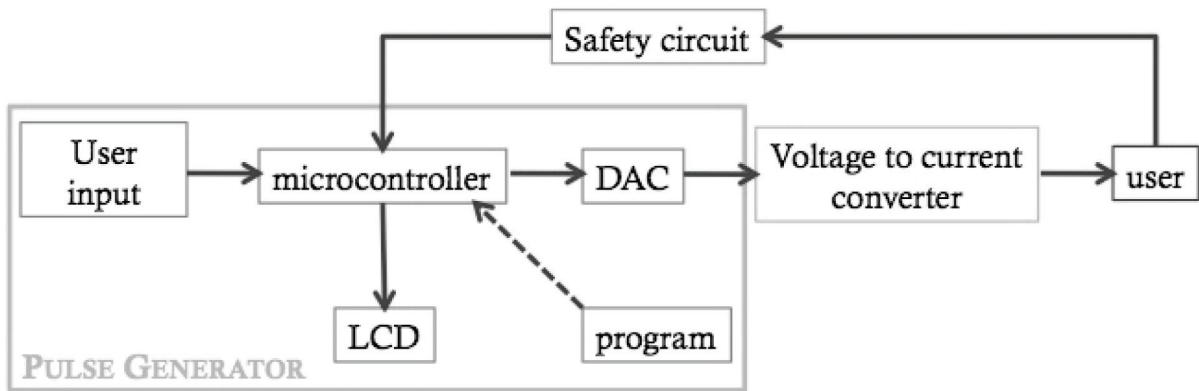

The electrical characteristics of TENS are chosen with a view to selectively activate different populations of nerve, as this is believed to produce different analgesic outcomes. A standard TENS device provides a range of possible ways that TENS currents could be delivered.

TENS provide four shape of electric current: monophasic, symmetric biphasic, asymmetric biphasic, and spike like biphasic. This electric current is produced with pulse duration within 100 μ s and 1000 μ s, pulse frequency within 2 pulses per second and 200 pulses per second. The

electric pulse is generated in three pattern such as continuous, burst, and amplitude modulation. The amplitude of electric current can also be adjusted from -50mA to 50mA with maximum load of 500 Ω .

Melzack and Wall (1965) provide a physiological rationale for electro analgesic effects. They said that the transmission of pain stimulus could be inhibited by activation of peripheral afferent with big diameter or by activation of descending pain inhibitory pathways.

Figure 2. Microcontroller-based pulse generator (Putra, 2005)

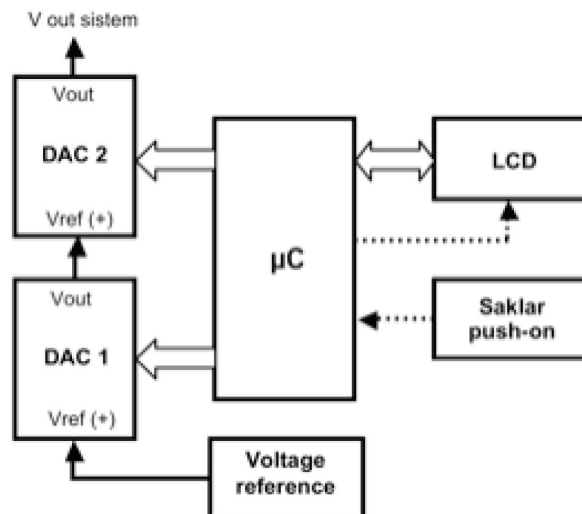

9 more pages are available in the full version of this document, which may be purchased using the "Add to Cart" button on the publisher's webpage:

www.igi-global.com/chapter/safety-system-design-simulation-transcutaneous/65709

Related Content

Social Exclusion of Refugees With a Disability in Australian Society Within the Context of Healthcare Quality Theory and E-Health

Hossein Adibi (2025). *International Journal of Reliable and Quality E-Healthcare* (pp. 1-20).

www.irma-international.org/article/social-exclusion-of-refugees-with-a-disability-in-australian-society-within-the-context-of-healthcare-quality-theory-and-e-health/372062

Health Economic Implications of Complications Associated With Pancreaticoduodenectomy: A Retrospective Cohort Cost Study

Jason Wang and Laurence Weinberg (2019). *Clinical Costing Techniques and Analysis in Modern Healthcare Systems* (pp. 144-167).

www.irma-international.org/chapter/health-economic-implications-of-complications-associated-with-pancreaticoduodenectomy/208282

An e-Healthcare Mobile Application: A Stakeholders' Analysis Experience of Reading

Niki Panteli, Barbara Pitsillides, Andreas Pitsillides and George Samaras (2007). *Web Mobile-Based Applications for Healthcare Management* (pp. 101-117).

www.irma-international.org/chapter/healthcare-mobile-application/31153

The Potential of Mobile Health in Nursing: The Use of Mobile Communication Technology in Plasma-Supported Outpatient Wound Care in Germany

Anne Kirschner, Stefanie Kirschner, Christian Seebauer and Bedriska Bethke (2017). *International Journal of Reliable and Quality E-Healthcare* (pp. 49-58).

www.irma-international.org/article/the-potential-of-mobile-health-in-nursing/187036

From Healthcare Services to E-Health Applications: A Delivery System-Based Taxonomy

Riccardo Spinelli and Clara Benevolo (2018). *Health Care Delivery and Clinical Science: Concepts, Methodologies, Tools, and Applications* (pp. 909-940).

www.irma-international.org/chapter/from-healthcare-services-to-e-health-applications/192711