

Confirmatory Factor Analysis of the End–User Computing Satisfaction Instrument: A Replication

William J. Doll
The University of Toledo

Weidong Xia
The University of Pittsburgh

Cross-validation is an important and often neglected step in the scientific process. Measurement models can vary across samples and must be tested and retested before they are accepted as valid. In a review of user satisfaction instruments, Klenke concludes that there is an appalling lack of effort to cross-validate MIS instruments and calls for efforts to retest the End–User Computing Satisfaction (EUCS) instrument using new data. Using different sampling methods and a new sample of 359 respondents, this study replicates an earlier confirmatory factor analysis of the EUCS instrument. This replication suggests that the EUCS instrument is robust (i.e., not affected by sampling methods) and can be used with confidence to evaluate information systems.

User satisfaction is considered one of the most important measures of information systems success (DeLone and McLean, 1992; Ives and Olson, 1984). The structure and dimensionality of the user satisfaction construct are important theoretical issues that have received considerable attention (Zmud, 1978; Larcher and Lessig, 1980; Swanson, 1982; Ives, Olson and Baroudi, 1983; Doll and Torkzadeh, 1988). These issues have not been fully resolved. Most of this literature focuses on explaining what user satisfaction is by identifying its components, but the discussion usually suggests that user

satisfaction may be a single construct. Substantive research studies use a total score obtained by summing items (i.e., implying that user satisfaction is a single first-order construct).

Several researchers have stressed the importance of developing standardized instruments for measuring user satisfaction (Ives and Olson, 1984; Straub, 1989; DeLone and McLean, 1992). The research cycle (Mackenzie and House, 1979; McGrath, 1979) for developing a standardized instrument has two steps: (1) exploratory studies that develop hypothesized measurement model(s) via the analysis of empirical data from a referent population; and (2) confirmatory studies that test hypothesized measurement model(s) against new data gathered from the same referent population.

Only a few researchers have devoted serious attention to the measurement of user satisfaction (e.g., Jenkins and Ricketts, 1979; Bailey and Pearson, 1983; Ives, Olson and Baroudi, 1983; Goodhue, 1988; Baroudi and Orlikowski, 1988; Doll and Torkzadeh, 1988). These instrument development efforts have been exploratory studies or replications using exploratory techniques. Confirmatory factor analysis is needed to complete the research cycle; it provides a more rigorous and systematic test of alternative factor structures than is possible within the framework of exploratory factor analysis (Bollen, 1989; Joreskog and Sorbom, 1989).

In an exploratory study, Doll and Torkzadeh (1988) propose an end-user computing satisfaction (EUCS) measurement model that consists of five first-order factors (content, format, accuracy, ease of use, timeliness) measured by 12 items. The instrument is illustrated in the appendix. A single second-order factor is interpreted as EUCS. The first-order factors provide a framework for explaining the EUCS construct by identifying underlying components. Interpretations given to the factors represent post-hoc judgements. Thus, Doll and Torkzadeh's proposed measurement model is best treated as a hypothesis that must be tested, and retested, before any interpretation of the structure or dimensionality of the EUCS construct is accepted as valid (Klenke, 1992).

Zmud and Boynton (1991) found that the EUCS instrument was one of only three scales (out of 119 scales examined) that met three criteria (i.e., multiple items, reliability, validity) for a well developed instrument. Klenke (1992) concluded that there is an appalling lack of effort to cross-validate MIS instruments. She called for the EUCS instrument to be administered in different samples to establish the invariance (or lack of it) of the reported factor structure.

Using a new sample of 409 respondents, Doll, Xia and Torkzadeh (1994) conducted a confirmatory factor analysis that supported the EUCS instrument. This research gathers additional data using different sampling methods to replicate tests of the structure, validity, and reliability of the EUCS instrument. Replication using new data is an important check on whether the measurement model is robust (i.e., the structure of the measurement model is not a sampling fluke or an artifact of sampling methods). In theory, the importance of replication is widely recognized. In practice replicative studies appear far too infrequently (Bollen, 1989). In the words of Popper (1959), "We do not take even our own observations quite seriously, or accept them as scientific observations, until we have repeated and tested them."

Research Methods

Confirmatory factor analysis involves the specification and estimation of one or more putative models of factor structure, each of which proposes a set of latent variables (factors) to account for covariances among a set of observed variables (Joreskog and Sorbom, 1989; Bagozzi, 1980; Bollen, 1989). It requires a priori designation of plausible factor patterns from previous theoretical or empirical work. These plausible alternative models are then explicitly tested statistically against sample data. Confirmatory factor analysis has been used extensively in psychology, marketing, and counseling for validating instruments by testing alternative models (e.g., Byrne, 1989; Marsh and Hocevar, 1985; Marsh and Hocevar, 1988; Thacker, Fields and Tetrick, 1989; Marsh, 1985; Harvey, Billings and Nilan, 1985; and Kumar and Sashi, 1989).

In this study, LISREL VIII (Joreskog and Sorbom, 1991) was used to describe alternative models and test the fit

of each hypothesized model against the sample data. First, based on logic, theory and previous studies, four plausible alternative models of factor structure are proposed (see Figure 1). Without respecifying the models, model-data fit and evidence of a higher-order factor is assessed using several goodness-of-fit indexes. One model is selected as representing the underlying factor structure in the sample data. Second, confirmatory factor analysis is used to assess the reliability and validity of the factors and items in the selected model.

The Alternative Models

Model 1 hypothesizes one first-order factor (EUCS) accounting for all the common variance among the twelve items. Theory as well as substantive research studies using user satisfaction instruments, including EUCS, typically assume that user satisfaction is a single first-order construct. This assumption is implicit in the typical practice of scaling the satisfaction construct by adding individual items to obtain a total score. Doll and Torkzadeh (1988) scale EUCS by using such a totalscore, implying that one first-order factor is a plausible model of underlying data structure.

Model 2 hypothesizes that the twelve items form into five uncorrelated or orthogonal first-order factors (content, accuracy, format, ease of use, timeliness). Doll and Torkzadeh's use of varimax (orthogonal) rotation should have resulted in five uncorrelated factors; thus, Model 2 is considered a plausible alternative model of underlying data structure. Examining this model also provides a test of the necessity of incorporating correlated factors by enabling a comparison of the increase in fit between uncorrelated and correlated models.

Model 3 hypothesizes that the five first-order factors are correlated with each other. Doll and Torkzadeh (1988) clearly lay a foundation for this model in their discussion of the large common variance among the 12 items (see page 265). The original study used corrected-item total correlations and correlations with an overall criterion (a global user satisfaction measure) to eliminate items. This elimination method resulted in 12 items that had substantial common variance. The factor scores from a varimax rotation are orthogonal, but the subscales are not necessarily orthogonal (uncorrelated). If the items have a large amount of common variance, scales based on these items may be correlated. This model was not explicitly proposed by Doll and Torkzadeh, yet it is plausible because of common variance among the 12 items.

Model 4 hypothesizes five first-order factors and one second-order factor (EUCS). This model was tested because it was proposed by Doll and Torkzadeh (see Figure 3 on page 268 of their 1988 article). If first-order factors are correlated, it is possible that the correlations between first-order factors is statistically "caused" by a single second-order factor (Tanaka and Huba, 1984).

Criteria for Comparing Model-Data Fit

Because no one statistic is universally accepted as an index of model adequacy, our interpretation of results empha-

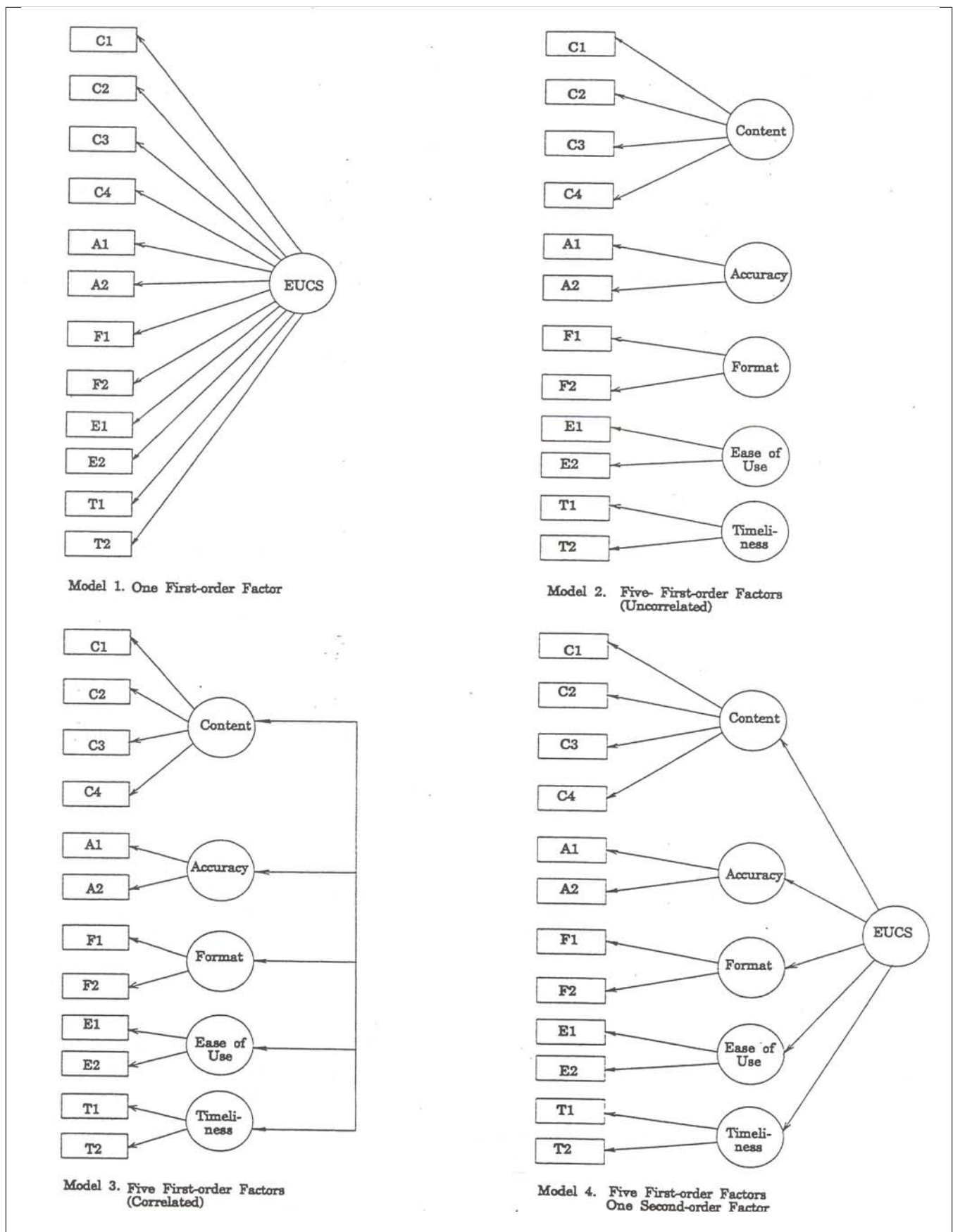

Figure 1: One First-order Factor

sizes substantive issues, practical considerations, and several measures of fit. In this study, relative or incremental fit indexes reflecting the improvement in fit of one model over an alternative (i.e., ratio of chi-square to degrees of freedom, normed fit index (NFI), and target coefficient) are used to compare models. Absolute indexes of goodness-of-fit such as chi-square, goodness-of-fit index (GFI), adjusted goodness-of-fit index (AGFI), and root mean square residual (RMSR) are used to evaluate individual models. The researchers used the same criteria that were used in the original confirmatory study (Doll, Xia, and Torkzadeh, 1994) to facilitate comparison.

Although the chi-square statistic is a global test of a model's ability to reproduce the sample variance/covariance matrix, it is sensitive to sample size and departures for multivariate normality (Bollen, 1989). Thus, the chi-square statistic must be interpreted with caution in most applications (Joreskog and Sorbom, 1989). Many researchers interpret GFI or AGFI scores in the .80 to .89 range as representing reasonable fit; scores of .90 or higher are considered evidence of good fit. Smaller values of the RMSR are associated with better fitting models with scores below .05 considered as evidence of good fit (Joreskog and Sorbom, 1984; Byrne, 1989).

The ratio of chi-square to the degrees of freedom provides information on the relative efficiency of competing models in accounting for the data. Researchers have recommended using ratios as low as 2 or as high as 5 to indicate a reasonable fit (Marsh and Hocevar, 1985). The NFI assesses the fit of a model relative to the fit of a null model by scaling the chi-square value from 0 to 1 with larger values indicating better models (Bentler and Bonett, 1980). Well-fitting models generally yield normed fit indexes of at least .90, i.e., only a relatively small amount of variance remains unexplained by the model (Harvey, Billings and Nilan, 1985). The target coefficient index (the ratio of chi-square of the first-order model to the chi-square of the higher-order model) is an index used to provide evidence of the existence of a higher-order construct (Marsh & Hocevar, 1985). It reflects the extent to which the higher-order factor model accounts for covariation among the first-order factors and can be interpreted as the percent of variation in the first-order factors that can be explained by the second-order construct.

Evaluating Validity and Reliability

In confirmatory factor analysis, factor loadings can be viewed as regression coefficients in the regression of observed variables on latent variables. On the first-order level of measurement models, the standard factor loadings of observed variables (items) on latent variables (factors) are estimates of the validity of the observed variables. For second or higher levels, the standard structural coefficients of factors on higher-order constructs are estimates of the validity of the factors. The larger the factor loadings or coefficients – as compared with their standard errors and expressed by the corresponding t values – the stronger is the evidence that the

measured variables or factors represent the underlying constructs (Bollen, 1989; Mueller, 1994).

Confirmatory factor analysis enables us to estimate the reliability of individual items, factors, and the overall instrument. On the first-order level of measurement models, the proportion of variance (R-square) in the observed variables that is accounted for by the latent variables influencing them can be used to estimate the reliability of the observed variables (items). For second or higher levels, the proportion of variance (R-square) in the latent variables (factors) that is accounted for by the higher-order construct influencing them can be used to estimate the reliability of the latent factors (Bollen, 1989; Mueller, 1993). The total coefficient of determination for observed variables is an estimate of the reliability of the overall instrument.

The Confirmatory Sample

To assess the robustness of the measurement model, the data gathering methods were quite different than those used in the original exploratory study (Doll & Torkzadeh, 1988) or the first confirmatory study (Doll, Xia and Torkzadeh, 1994). In these prior studies, data were gathered through the MIS directors who identified the major end-users and applications. In this study, the subjects were working students in the capstone business policy course at a mid-west urban university. Only working students who used a computer application in their job were asked to complete one of three versions of the questionnaire. Each version used the same items but randomized their sequence. The students were asked to identify the application they used most frequently by entering its name on the cover page of the questionnaire; then, they were asked to answer questions about this specific application.

The sample consists of 359 computer end-users from 122 organizations. The sample represents 146 different applications including accounts payable, accounts receivable, budgeting, customer service, service dispatching, engineering analysis, human resource management, E-mail, work order control, general ledger, manpower planning, financial planning, inventory, order entry, payroll, personnel, production planning, purchasing, quality, marketing research, sales analysis, and student data. The large number of organizations and the variety of applications support the generalizability of the findings.

Respondents were asked to identify their position within the organization; they responded as follows: 7 top level managers, 61 middle managers, 44 first level supervisors, 121 professional employees without supervisory responsibility, and 110 operating personnel. Sixty two percent of the respondents stated that their application was a personal computer (micro) application. Thirty two percent of the computer applications were developed primarily by end-users but only twenty two of the respondents personally developed the applications themselves. Sixty percent of the applications provided data analysis capabilities (spreadsheet, modeling, simulation, optimization or statistical routines). Sixty percent of the appli-

Model	Chi-sqr (df)	Chi-sqr/df	NFI	GFI	AGFI	RMSR
0. Null model	3257.43 (66)	49.36	—	.21	.07	.450
1. 1 First-order factor	458.48 (54)	8.49	.86	.82	.73	.058
2. 5 First-order factors (Uncorrelated)	1398.21 (59)	23.70	.57	.58	.44	.410
3. 5 First-order factors (Correlated)	119.08 (44)	2.71	.96	.95	.90	.024
4. 5 First-order factors 1 Second-order factor	175.37 (49)	3.58	.95	.92	.88	.034

Table 1: Goodness-of-Fit Indexes for Alternative Models (n=359)

Observed Variables			Latent Variables		
Item	Factor Loading	R-Square (Reliability)	Factor	Std. Structure Coefficient	R-Square (Reliability)
C1	.83*	.70	Content	.97 (18.18)	.94
C2	.85 (19.96)	.73			
C3	.80 (17.98)	.64			
C4	.82 (18.78)	.68			
A1	.87*	.75	Accuracy	.83 (15.43)	.69
A2	.89 (18.58)	.75			
F1	.85*	.72	Format	.93 (17.58)	.87
F2	.86 (19.52)	.73			
E1	.84*	.71	Ease of Use	.71 (12.01)	.50
E2	.88 (15.45)	.78			
T1	.84*	.70	Timeliness	.98 (18.41)	.95
T2	.76 (16.38)	.58			

Note: * indicates a parameter fixed at 1.0 in the original solution.
t-values for item factor loadings and factor structural coefficients are indicated in parentheses.

**Table 2: Standardized Parameter Estimates and t-values for Model Four (n=359)
5 First-order Factors, 1 second-order Factor**

cations provided a data base with flexible inquiry capabilities. Eighty percent of the respondents were required to use the application in their work and twenty percent were voluntary users.

Results¹

The goodness-of-fit indexes for the alternative models (Figure 1) and the null model are summarized in Table 1. A proper solution was obtained for the null model and each hypothesized measurement model. The primary purpose of the null model is to establish the zero-point for the NFI. As expected, the null model provides a poor fit to the data as evidenced by a ratio of chi-square to degrees of freedom of 49.36. Model 1 provides a substantially better fit relative to the null model for all indexes of goodness-of-fit. All goodness-of-fit indexes indicate that Model 1 has substantially better model-data fit than model 2. However, by normal standards, neither Model 1 nor Model 2 are close to being considered a

good fit with the sample data.

Model 3 shows good model-data fit as indicated by absolute indexes (GFI, AGFI, and RMSR) and provides substantial improvement over Model 1 as evidenced by the changes in the NFI index (from .86 to .96) and the ratio of chi-square to degrees of freedom (from 8.49 to 2.71). From an empirical perspective, this model provides a more than satisfactory solution.

Model 4 shows reasonable model-data fit as indicated by absolute indexes (GFI, AGFI, and RMSR). As expected for a second-order model, Model 4's GFI and AGFI scores are slightly lower than its first-order counterpart (Model 3). Like Model 3, it provides substantial improvement over Model 2 as evidenced by the changes in the NFI index (from .86 to .95) and the ratio of chi-square to degrees of freedom (from 8.49 to 3.58). Thus, the results suggest that both Model 3 and Model 4 are satisfactory and competing representations of underlying structure of the instrument.

The target coefficient was used to test for the existence

of a higher-order user satisfaction construct. Using Model 3 as the target model, the target coefficient is the ratio of chi-square of Model 3 to chi-square of Model 4. In this case, a target coefficient of .68 provides reasonable evidence of a second-order user satisfaction construct. Sixty eight percent of the variation in the five first-order factors in Model 3 is explained by Model 4's user satisfaction construct.

In comparing first-order and second-order models, it is important to realize that the higher-order factors are merely trying to explain the covariation among the first-order factors in a more parsimonious way (i.e., one that requires fewer degrees of freedom). Consequently, even when the higher-order model is able to explain effectively the factor covariations, the goodness-of-fit of the higher-order model can never be better than the corresponding first-order model.

Since theory in this field suggests the existence of a single overall user satisfaction construct, Model 4 is of greater theoretical interest than Model 3. Also, in this study, there is reasonable evidence of a single second-order construct. Both Model 3 and Model 4 enable us to examine the validity and reliability of individual items. Estimates of item validity and reliability are not sensitive to the addition of a second-order factor; thus, conclusions concerning the validity and reliability of the twelve items would be the same regardless of which model was selected. Model 4 has the additional advantage of providing estimates of the validity and reliability of the latent

factors (content, accuracy, format, ease of use, and timeliness). For these reasons, the researchers recommend Model 4 and proceed with the analysis of the validity and reliability of factors and items assuming this second-order model.

LISREL'S maximum likelihood estimates of Model 4's standardized parameter estimates are presented in Table 2 for both latent variables and observed variables. For the observed variables, Table 2 presents factor loadings, their corresponding t values, and R-square values. With t values above 2.0 being considered significant, factor loadings can be interpreted as indicators of validity for the twelve items. All items have large (greater than .76) and significant loadings on their corresponding factors, indicating evidence of good construct validity. The proportion of the variances, or R-square, in the observed variables that is accounted for by its corresponding latent variable is used as an indicator of each item's common factor reliability. R-square values range from .58 to .78, indicating acceptable reliability for all items.

For the latent variables, Table 2 presents the standard structural coefficients, their corresponding t values, and R-square values. Standard structural coefficients can be interpreted as indicators of validity of the latent factors as components of the EUCS construct. With t values above 2.0 being considered significant, all factors have large (greater than .71) and significant structural coefficients, indicating good construct validity. R-square values for each of the five latent factors range from .50 to .95, indicating acceptable reliability

Appendix: The EUCS Instrument

This questionnaire is to be completed by individuals who use the application named below:

Name of Application _____

User Satisfaction:

Please circle the response below which best describes your satisfaction with this application.

	ALMOST	SOME OF	ABOUT HALF	MOST OF	AL-
	NEVER	THE TIME	OF THE TIME	THE TIME	AL-
MOST					
WAYS					
C2. Does the information content meet your needs?	1	2	3	4	5
F1. Do you think the output is presented in a useful format?	1	2	3	4	5
A1. Is the system accurate?	1	2	3	4	5
T2. Does the system provide up-to-date information?	1	2	3	4	5
C4. Does the system provide sufficient information?	1	2	3	4	5
T1. Do you get the information you need in time?	1	2	3	4	5
E2. Is the system easy to use?	1	2	3	4	5
C1. Does the system provide the precise information you need?	1	2	3	4	5
A2. Are you satisfied with the accuracy of the system?	1	2	3	4	5
C3. Does the system provide reports that seem to be just?	1	2	3	4	5
E1. Is the system user friendly?	1	2	3	4	5
F2. Is the information clear?	1	2	3	4	5

Discussion and Conclusions

Confirmatory factor analysis results should always be interpreted with caution. The criteria for comparing models and judging goodness-of-fit are relative rather than absolute. There are no standard cutoff values for evaluating model-data fit or the existence of higher-order constructs. Also, the fact that a sample fits a model does not necessarily imply that the model represents reality (i.e., that it is the ultimate solution). A final word of caution is in order. Confirmatory findings should not be taken too seriously as scientific observations unless they can be replicated.

The comparison of alternative models (Table 1) and the standardized parameter estimates for the higher order model (Table 2) closely parallels the results reported in the original confirmatory study (Doll, Xia and Torkzadeh, 1994). Eight of the 12 item loadings are identical to two digits past the decimal; the other four (C3, F1, F2, and T1) are slightly higher in this study. The standard structural coefficients display more variability between samples but are adequate (above .71) in both samples. The replication of these results in another sample enhances our confidence in the generalizability of the EUCS instrument.

These results suggest that the data-model fit obtained in the original confirmatory study was not an artifact of the sampling methods. Using quite different research methods, this study confirms earlier conclusions concerning the structure and dimensionality of the user satisfaction construct. User satisfaction can be viewed both as a multifaceted construct consisting of five subscales (content, accuracy, format, ease of use and timeliness) and as a single second-order construct. This replication provides evidence that the EUCS instrument is a robust measure of user satisfaction.

Endnote

¹ The correlation matrix used as input for the confirmatory analyses as well as the item and 12-item scale means and standard deviations are available from the authors upon request.

References

- Bagozzi, R.P., (1980). *Causal Modelling in Marketing*, Wiley & Sons, New York, NY.
- Bailey, J.E. & Pearson, S.W., (1983). "Development of a Tool for Measuring and Analyzing Computer User Satisfaction," *Management Science*, (29:5), 530-545.
- Baroudi, J.J. & Orlikowski, W.J., (1988). "A Short-Form Measure of User Information Satisfaction: A Psychometric Evaluation and Notes on Use," *Journal of Management Information Systems*, (4:4), 44-59.
- Bentler, P.M. & Bonnet, D.G., (1980). "Significance Tests and Goodness-of-fit in the Analysis of Covariance Structure," *Psychological Bulletin*, (88:3), 588-606.
- Bollen, K.A., (1989). *Structural Equations with Latent Variables*, Wiley & Sons, New York, NY.
- Byrne, B.M., (1989). *A Primer of LISREL: Basic Applications and Programming for Confirmatory Factor Analytic Models*, Springer-Verlag, New York, NY.
- DeLone, W. & McLean, E., (1992). "Information Systems Success: The Quest for the Dependent Variable," *Information Systems Research*, (3:1), 60-95.
- Doll, W.J. & Torkzadeh, G., (1988). "The Measurement of End-User Computing Satisfaction," *MIS Quarterly*, (12:2), 259-274.
- Doll, W.J., Xia, Weidong & Torkzadeh, G., (1994). "A Confirmatory Factor Analysis of the End-User Computing Satisfaction Instrument," *MIS Quarterly*, (18:4), 357-369.
- Goodhue, D.L., (1988). Supporting Users of Corporate Data: The Effects of I/S Policy Choices, unpublished doctoral dissertation, Massachusetts Institute of Technology, Boston, Mass.
- Harvey, R.J., Billings, R. & Nilan, K.J., (1985). "Confirmatory Factor Analysis of the Job Diagnostic Survey: Good News and Bad News," *Journal of Applied Psychology*, (70:3), 461-468.
- Ives, B., Olson, M., & Baroudi, J.J., (1983). "The Measure of User Information Satisfaction," *Communications of ACM*, (26:10), 785-793.
- Ives, B. & Olson, M., (1984). "User Involvement and MIS Success: A Review of Research," *Management Science*, (30:5), 586-603.
- Jenkins, A.M. & Ricketts, J.A., (1979). "Development of an Instrument to Measure User Information Satisfaction with Management Information Systems," Working Paper, Indiana University, Bloomington.
- Joreskog, K. & Sorbom, D., (1984). *LISREL VI: Analysis of Linear Structural Relationships by the Method of Maximum Likelihood*, National Educational Resources, Chicago, Ill.
- Joreskog, K. & Sorbom, D., (1991). *LISREL VIII User's Guide*, Scientific Software, Inc., Mooresville, Indiana.
- Klenke, K., (1992). Construct Measurement in Management Information Systems: A Review and Critique of User Satisfaction and User Involvement Instruments, *INFOR*, (30:4), 325-348.
- Kumar, A. & Sashi, C.M., (1989). "Confirmatory Analysis of Aggregate Hierarchical Market Structures: Inferences from Brand-Switching Behavior," *Journal of Marketing Research*, (26), 444-453.
- Larcher, D.F. & Lessig, V.P., (1980). "Perceived Usefulness of Information: A Psychometric Examination," *Decision Sciences*, (11:1), 121-134.
- Mackenzie, K.D., & House, R., (1979). "Paradigm Development in the Social Sciences," in *Research in Organizations: Issues and Controversies*, R. T. Mowday and R. M. Steers (eds.), Goodyear Publishing, Santa Monica, CA., 22-38.
- Marsh, H.W., (1985). "The Structure of Masculinity/Femininity: an Application of Confirmatory Factor Analysis to Higher-order Factor Structures and Factorial Invariance," *Multivariate Behavioral Research*, (20), 427-449.
- Marsh, H.W. & Hocevar, D., (1988). "A New, More Powerful Approach to Multitrait-multimethod Analysis: Application of Second-order Confirmatory Factor Analysis," *Journal of Applied Psychology*, (73:1), 107-117.
- Marsh, H.W. & Hocevar, D., (1985). "Application of Confirmatory Factor Analysis to the Study of Self-concept: First- and Higher-order Factor Models and Their Invariance Across Groups," *Psychological Bulletin*, (97:3), 562-582.
- McGrath, J., (1979). "Toward a 'Theory of Method' for Research on Organizations," in *Research in Organizations: Issues and Controversies*, R.T. Mowday and R.M. Steers (eds.), Goodyear Publishing, Santa Monica, CA., 4-21.

Mueller, R.O., (1994). *Basic Principles of Structural Equation Modeling: an Introduction to LISREL and EQS*.

Popper, K.R., (1968). *The Logic of Scientific Discovery*, Harper, New York, N.Y.

Straub, D.W., (1989). "Validating Instrument in MIS Research," *MIS Quarterly*, (13:2), 147–169.

Swanson, E. B., (1982). "Measuring User Attitudes in MIS Research: A Review," *Omega*, (10:2), 157–165.

Tanaka, J.S. & Huba, G.J., (1984). "Confirmatory Hierarchical Factor Analysis of Psychological Distress Measures," *Journal of Personality and Social Psychology*, (46:3), 621–635.

Thacker, J.W., Fields, M.W. & Tetrick, L.E., (1989). "The Factor Structure of Union Commitment: An Application of Confirmatory Factor Analysis," *Journal of Applied Psychology*, (74:2), 228–232.

Zmud, R.W., (1978). "Concepts, Theories and Techniques--An Empirical Investigation of the Dimensionality of the Concept of Information," *Decision Sciences*, (9), 187-195.

Zmud, R. W. & Boynton, A.C., (1991). "Survey Measures and Instruments in MIS: Inventory and Appraisal," in Kramer, K. L. and Cash, J.I., Jr. (Eds.) *The Information Systems Research Challenge: Survey Research Methods*, Harvard Business School, Boston, Massachusetts.

Dr. William J. Doll is a Professor of MIS and Strategic Management at the University of Toledo. Dr. Doll holds a doctoral degree in Business Administration from Kent State University and has published extensively on information system and manufacturing issues in academic and professional journals including Management Science, Communications of the ACM, MIS Quarterly, Academy of Management Journal, Decision Sciences, Omega, Information & Management, Datamation, and Datapro. Dr. Doll has published extensively in a variety of topics including computer integrated manufacturing, executive steering committees, top management involvement in MIS development, strategic information systems, information systems downsizing, and end-user computing. Dr. Doll has developed a widely used research instrument to measure end-user computing satisfaction.

Weidong Xia is a Ph.D. candidate in Katz Graduate School of Business at the University of Pittsburgh. He holds a M.Sc. in Management Science and Information Systems from Beijing University of Aero. and Astro. He was a Lecturer and Deputy Director of the Division of Information Systems and Management Science at Beijing University of Aero. and Astro. before joining the University of Toledo. He is a member of DSI and POMS. He has co-authored two textbooks in computer technology and information systems analysis and design in China. His research articles have been published in MIS Quarterly, Scientific Research of BUAA and Standardization and Quality. One of his current research interests is management of the information systems function.

0 more pages are available in the full version of this document, which may be purchased using the "Add to Cart" button on the publisher's webpage:

www.igi-global.com/article/confirmatory-factor-analysis-end-user/55740

Related Content

Maximum-Entropy-Based Decision-Making Trial and Evaluation Laboratory and Its Application in Emergency Management

Yuelin Che, Yong Deng and Yu-Hsi Yuan (2022). *Journal of Organizational and End User Computing* (pp. 1-16).

www.irma-international.org/article/maximum-entropy-based-decision-making-trial-and-evaluation-laboratory-and-its-application-in-emergency-management/302891

Validating the End-User Computing Satisfaction Instrument for Online Shopping Systems

Chung-Tzer Liu and Yi Maggie Guo (2008). *Journal of Organizational and End User Computing* (pp. 74-96).

www.irma-international.org/article/validating-end-user-computing-satisfaction/3849

Two Experiments in Reducing Overconfidence in Spreadsheet Development

Raymond R. Panko (2008). *End-User Computing: Concepts, Methodologies, Tools, and Applications* (pp. 875-892).

www.irma-international.org/chapter/two-experiments-reducing-overconfidence-spreadsheet/18226

Similarity Discriminating Algorithm for Scientific Research Projects

Chong Li, Jinjie Zhang, Anyu Wang, Xuemin Liu, Yunchun Sun, Shibo Zhang, Zhixia Ji and Justin Z. Zhang (2023). *Journal of Organizational and End User Computing* (pp. 1-16).

www.irma-international.org/article/similarity-discriminating-algorithm-for-scientific-research-projects/332008

Mobile Agent Based Network Defense System in Enterprise Network

Yu Cai (2013). *Mobile and Handheld Computing Solutions for Organizations and End-Users* (pp. 54-69).

www.irma-international.org/chapter/mobile-agent-based-network-defense/73206