



Viterbi Decoder in Hardware

Mário Pereira Véstias
 Instituto Politécnico de Lisboa, Portugal

INTRODUCTION

Trellis decoding is used to recover encoded information that was corrupted during transmission over a noisy channel. The Viterbi algorithm is the most well known trellis-based maximum likelihood decoding algorithm. The Viterbi algorithm is executed by a Viterbi decoder. Different hardware solutions may be considered to implement a Viterbi decoder with different design requirements in terms of area, performance, power consumption, among others. The most appropriate solution depends on the metric requirements of the application as well as on the target technology.

Properties of the Viterbi algorithm are used to simplify and improve the architecture of the Viterbi decoder. In particular, statistical properties of the Viterbi algorithm are used to design parallel Viterbi decoders with very high data decoding rates.

The article focuses on the implementation of a Viterbi decoder in hardware, including optimizations to improve the area and performance.

BACKGROUND

Generically, a communication system includes a channel encoder at the transmitter and a channel decoder at the receiver. Encoding the bit stream to be transmitted reduces the energy per data bit needed to achieve the same bit error rate (BER) over a noisy channel compared to a non-coded transmission. A better channel code needs lower energy to obtain a particular BER.

Convolutional Encoder

Two major classes of binary codes are block codes and convolution codes. In this article we are only concerned with convolution codes (P. Elias, 1955). Convolution codes operate over a continuous bit stream. A convolutional encoder is used to generate the encoded bitstream. A typical implementation consists on a shift register and a set of modulo-2 addition. The content of the shift register defines the state of the encoder (s bits), from which we obtain a finite state machine with $m = 2^s$ states. Figure 1 shows an example of a

Figure 1. Convolution encoder with rate 1/2

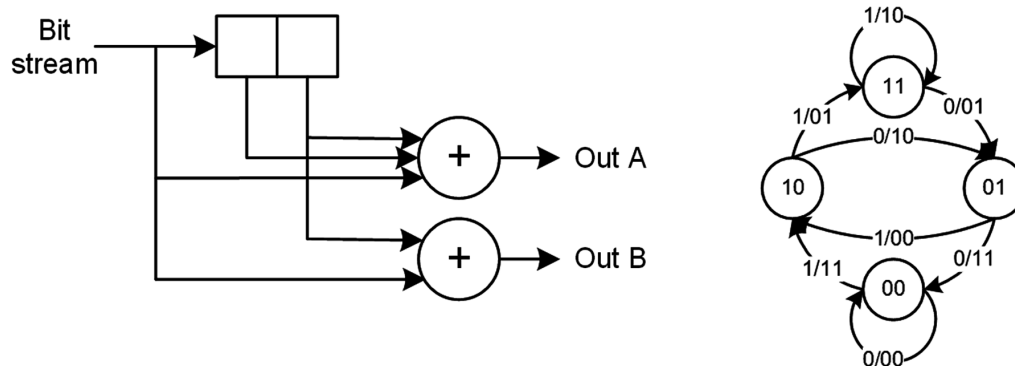

DOI: 10.4018/978-1-5225-2255-3.ch549

convolution encoder with rate 1/2 (rate 1/c generates c bits for each input bit) and its state machine.

An alternative way to represent the behavior of the encoder was proposed by Forney (G. D. Forney, Jr., 1967) designated *trellis representation*. A trellis is one of the most convenient ways to visualize the behavior of the decoding algorithms (see Figure 2).

Each node in the trellis represents a state of the FSM. After m time steps, the trellis is full and the branch pattern repeats indefinitely.

Most work on trellis decoding was dedicated to the codes with a rate of 1/2. This type of codes will provide the simplest trellis decoding since there are only two nodes leaving and entering a state.

Viterbi Algorithm

The Viterbi algorithm (VA) was proposed in 1967 by Andrew Viterbi (Viterbi, 1967). The algorithm decodes convolutional codes with an optimum non-sequential algorithm. Contrary to previous algorithmic solutions whose complexity increases exponentially with the length of the encoded sequence, the computational complexity of the Viterbi algorithm increases linearly with the length of the bit stream. The algorithm has three main steps: (1) branch metric calculation; (2) trellis calculation; and (3) traceback decoding.

The branch metric, bm , calculation determines the squared Euclidian distance, between the re-

ceived symbol, r_k , and the expected symbol associated with a branch of the trellis diagram, c_k , that is, $r_k - c_k$. At every time step, $|r_k - c_k|^2$ branch metrics are calculated since each state has two input branches.

The linear computation complexity of the VA is achieved by discarding unlikely branches in the trellis diagram using the Principle of Optimality (Bellman and Dreyfus, 1962). According to this, whenever two paths of the trellis diagram merge into the same state only the path with the best metric (most likely) must be kept. This path is designated *survivor path*. At each time step, this operation is applied to all paths and m survivor paths are obtained at each time step. Formally, a state metric, $sm(state)$ (see Figure 3), is updated as follows:

$$2 \times m$$

At each time step, the trellis calculation step obtains m decision symbols, one for each surviving branch. These symbols must be stored to help recover the symbols responsible for specific transitions during the traceback decoding step.

The trellis computation stops after a predetermined number of steps or after the decoding of the complete stream. From the m survivor paths, the final step (traceback decoding) starts in the state with the best metric and tracebacks through the

Figure 2. Trellis diagram of the encoder in Figure 1

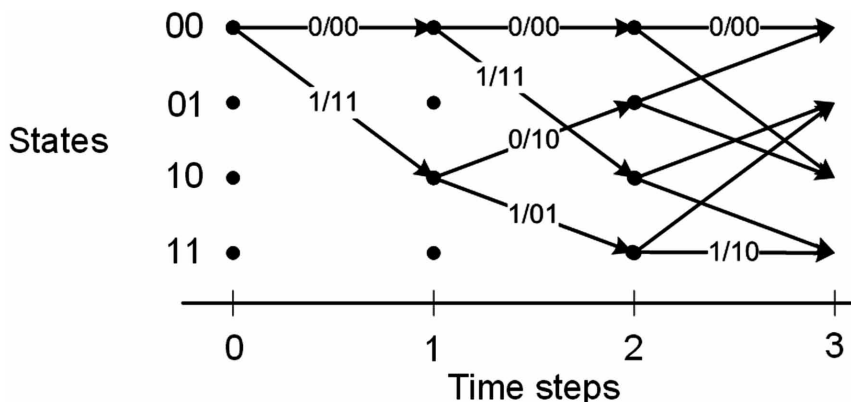

10 more pages are available in the full version of this document, which may be purchased using the "Add to Cart" button on the publisher's webpage:

www.igi-global.com/chapter/viterbi-decoder-in-hardware/184328

Related Content

State of the Art and Key Design Challenges of Telesurgical Robotics

Sajid Nisar and Osman Hasan (2018). *Encyclopedia of Information Science and Technology, Fourth Edition* (pp. 6872-6881).

www.irma-international.org/chapter/state-of-the-art-and-key-design-challenges-of-telesurgical-robotics/184383

Techniques for Analyzing Blogs and Micro-Blogs

Lynne M. Webb and Yuanxin Wang (2013). *Advancing Research Methods with New Technologies* (pp. 206-227).

www.irma-international.org/chapter/techniques-analyzing-blogs-micro-blogs/75947

Users Behavioral Intention Towards eGovernment in an African Developing Country

Ayankunle A. Taiwo (2018). *Encyclopedia of Information Science and Technology, Fourth Edition* (pp. 3654-3666).

www.irma-international.org/chapter/users-behavioral-intention-towards-egovernment-in-an-african-developing-country/184074

International Students in Online Courses

María Ángeles Rodríguez Manzanares (2018). *Encyclopedia of Information Science and Technology, Fourth Edition* (pp. 3900-3909).

www.irma-international.org/chapter/international-students-in-online-courses/184098

Adoption and Use of Mobile Money Services in Nigeria

Olayinka David-West, Immanuel Ovemeso Umukoro and Omotayo Muritala (2018). *Encyclopedia of Information Science and Technology, Fourth Edition* (pp. 2724-2738).

www.irma-international.org/chapter/adoption-and-use-of-mobile-money-services-in-nigeria/183984