

# Multilayer Optimization Approach for Fuzzy Systems

**Ivan N. Silva**

*University of São Paulo, Brazil*

**Rogério A. Flauzino**

*University of São Paulo, Brazil*

## INTRODUCTION

The design of fuzzy inference systems comes along with several decisions taken by the designers since it is necessary to determine, in a coherent way, the number of membership functions for the inputs and outputs, and also the specification of the fuzzy rules set of the system, besides defining the strategies of rules aggregation and defuzzification of output sets. The need to develop systematic procedures to assist the designers has been wide because the trial and error technique is the unique often available (Figueiredo & Gomide, 1997).

In general terms, for applications involving system identification and fuzzy modeling, it is convenient to use energy functions that express the error between the desired results and those provided by the fuzzy system. An example is the use of the mean squared error or normalized mean squared error as energy functions. In the context of systems identification, besides the mean squared error, data regularization indicators can be added to the energy function in order to improve the system response in presence of noises (from training data) (Guillaume, 2001).

In the absence of a tuning set, such as happens in parameters adjustment of a process controller, the energy function can be defined by functions that consider the desired requirements of a particular design (Wan, Hirasawa, Hu & Murata, 2001), i.e., maximum overshoot signal, setting time, rise time, undamped natural frequency, etc.

From this point of view, this article presents a new methodology based on error backpropagation for the adjustment of fuzzy inference systems, which can be then designed as a three layers model. Each one of these layers represents the tasks performed by the fuzzy inference system such as fuzzification, fuzzy rules inference and defuzzification. The adjustment

procedure proposed in this article is performed through the adaptation of its free parameters, from each one of these layers, in order to minimize the energy function previously specified.

In principle, the adjustment can be made layer by layer separately. The operational differences associated with each layer, where the parameters adjustment of a layer does not influence the performance of other, allow single adjustment of each layer. Thus, the routine of fuzzy inference system tuning acquires a larger flexibility when compared to the training process used in artificial neural networks. This methodology is interesting, not only for the results presented and obtained through computer simulations, but also for its generality concerning to the kind of fuzzy inference system used. Therefore, such methodology is expandable either to the Mandani architecture or also to that suggested by Takagi-Sugeno.

## BACKGROUND

In the last years it has been observed a wide and crescent interest in applications involving logic fuzzy. These applications include from consumer products, such as cameras, video camcorders, washing machines and microwave ovens, even industrial applications as control of processes, medical instrumentation and decision support systems (Ramot, Friedman, Langholz & Kandel, 2003).

The fuzzy inference systems can be treated as methods that use the concepts and operations defined by the fuzzy set theory and by fuzzy reasoning methods (Sugeno & Yasukawa, 1993). Basically, these operational functions include fuzzification of inputs, application of inference rules, aggregation of rules and defuzzification, which represents the crisp outputs of the fuzzy

system (Jang, 1993). At present time, there are several researchers engaged in studies related to the design techniques involving fuzzy inference systems.

The first type of design technique of fuzzy inference system has its focus addressed to enable the modeling of process from their expert knowledge bases, where both antecedent and consequent terms of the rules are always fuzzy sets, offering then a high semantic level and a good interpretability capacity (Mandani & Assilian, 1975). However, the applicability of this technique in the mapping of complex systems composed by several input and output variables has been an arduous task, which can produce as inaccurate results as poor performance (Guillaume, 2001)(Becker, 1991).

The second type of design technique of fuzzy inference system can be identified as being those that incorporate learning, in an automatic way, from data that are representing the behavior of the input and output variables of the process. Therefore, this design strategy uses a collection of input and output values obtained from the process to be modeled, which differs of the first design strategy, where the fuzzy system was defined using only the expert knowledge acquired from observation on the respective system. In a generic way, the methods derived from this second strategy can be interpreted as being composed by automatic generation techniques of fuzzy rules, which use the available data for their adjustment procedures (or training).

Among the main approaches belonging to this second design strategy, it has been highlighted the ANFIS (Adaptive-Network-based Fuzzy Inference Systems) algorithm proposed by Jang (1993), which is applicable to the fuzzy architectures constituted by real polynomial functions as consequent terms of the fuzzy rules, such as those presented by Takagi & Sugeno (1985) and Sugeno & Kang (1988). The more recent approaches, such as those proposed by Panella & Gallo (2005), Huang & Babri (2006) and Li & Hori (2006), are also belonging to this design strategy.

However, the representation of a process through these automatic architectures can implicate in interpretability reduction in relation to the created base of rules, whose consequent terms are expressed in most of the cases by polynomial functions, instead of linguistic variables (Kamimura, Takagi & Nakanishi, 1994).

Thus, the development of adjustment algorithms of fuzzy inference systems, which the consequent terms of the fuzzy rules are also represented by fuzzy sets, has been widely motivated.

### MAIN FOCUS OF THE CHAPTER

Considering the operational functions performed by the fuzzy inference systems, it is convenient to represent them by a three-layer model. Thus, the fuzzy inference

Figure 1. Fuzzy inference system composed by two inputs and one output

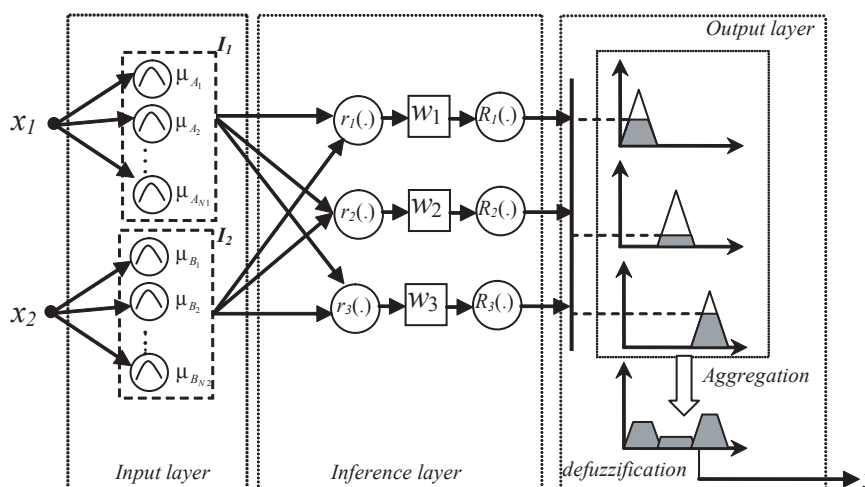

7 more pages are available in the full version of this document, which may be purchased using the "Add to Cart" button on the publisher's webpage: [www.igi-global.com/chapter/multilayer-optimization-approach-fuzzy-systems/10381](http://www.igi-global.com/chapter/multilayer-optimization-approach-fuzzy-systems/10381)

## Related Content

---

### Mining E-Mail Messages: Uncovering Interaction Patterns and Processes using E-Mail Logs

Wil M.P. van der Aalstand Andriy Nikolov (2008). *International Journal of Intelligent Information Technologies* (pp. 27-45).

[www.irma-international.org/article/mining-mail-messages/2437](http://www.irma-international.org/article/mining-mail-messages/2437)

### Ambulatory EEG Data Management System for Home Care Epileptic Patients: A Design Approach

Amol Pardhiand Suchita Varade (2022). *International Journal of Ambient Computing and Intelligence* (pp. 1-15).

[www.irma-international.org/article/ambulatory-eeeg-data-management-system-for-home-care-epileptic-patients/311500](http://www.irma-international.org/article/ambulatory-eeeg-data-management-system-for-home-care-epileptic-patients/311500)

### Knowledge-Based Recommendation Systems: A Survey

Sarah Bouraga, Ivan Jureta, Stéphane Faulknerand Caroline Herssens (2014). *International Journal of Intelligent Information Technologies* (pp. 1-19).

[www.irma-international.org/article/knowledge-based-recommendation-systems/114956](http://www.irma-international.org/article/knowledge-based-recommendation-systems/114956)

### AI for Insider Threat Detection and Employee Monitoring

Somasekhar Donthu, Abhishek Sharma, A.R. Arunarani, P. Krishnamoorthy, Vivekanand Pandey, K. Sumangalaand V. Bhoopathy (2026). *AI-Driven Intrusion Detection and Prevention for Business Cybersecurity* (pp. 269-294).

[www.irma-international.org/chapter/ai-for-insider-threat-detection-and-employee-monitoring/407729](http://www.irma-international.org/chapter/ai-for-insider-threat-detection-and-employee-monitoring/407729)

### Representation and Reference According to Peirce

Winfried Nöth (2011). *International Journal of Signs and Semiotic Systems* (pp. 28-39).

[www.irma-international.org/article/representation-reference-according-peirce/56445](http://www.irma-international.org/article/representation-reference-according-peirce/56445)